

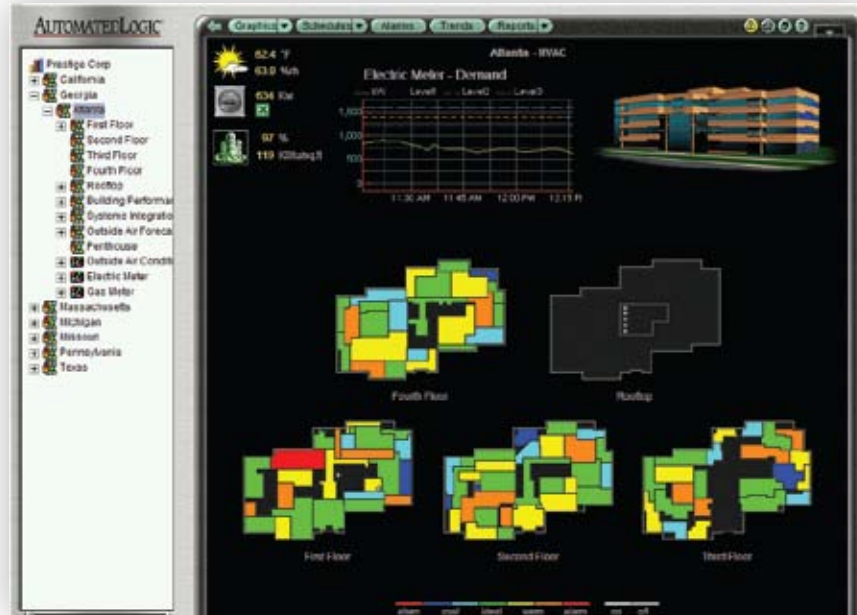

Powerful and Intuitive Front End for Building Control



Patents pending.

Navigational tree, intelligent use of color showing the status of zones and trends, plus superior graphics make WebCTRL rich in information yet easy to use.

Automated Logic's WebCTRL® is a building automation system that offers an intuitive user interface and powerful control features. Your building can be accessed from anywhere in the world using a standard web browser, eliminating the need for special software on the workstation. Through a browser you can access all building management functions including:

- setting and changing schedules,
- adjusting setpoints and other control properties,
- graphically trending important building conditions,
- viewing and acknowledging alarms, and
- running preconfigured and custom reports on energy usage, occupant overrides, tenant billing, and much more.

Developed entirely around proven open standards and web technologies, WebCTRL's server software runs on a variety of major platforms, including Windows®, Sun Solaris and Linux. Major databases are supported by the server, such as MS SQL Express, MS SQL Server, PostgreSQL and Oracle.

Key Features and Benefits

- Intuitive, comprehensive building operation with dynamic, interactive graphical access
- Completely designed around open standards
- Uses the language of the web (HTTP) to communicate over the Internet or intranet without special software or plug-ins
- Runs on multiple platforms including Windows, Linux, and Sun Solaris
- Advanced alarm management capabilities including email, pagers, network printers, etc.
- Uses sophisticated alarm escalation system protection with multi-level passwords and Secure Sockets Layer with 128-bit encryption for security
- Monitors and controls a wide variety of third party HV-ac and electrical equipment through a browser
- Fully compatible with legacy ALC Systems

AUTOMATED LOGIC
CORPORATION

1150 Roberts Boulevard
Kennesaw, Georgia 30144
770/429-3000
Fax 770/429-3001
www.automatedlogic.com

WebCTRL®

Specifications

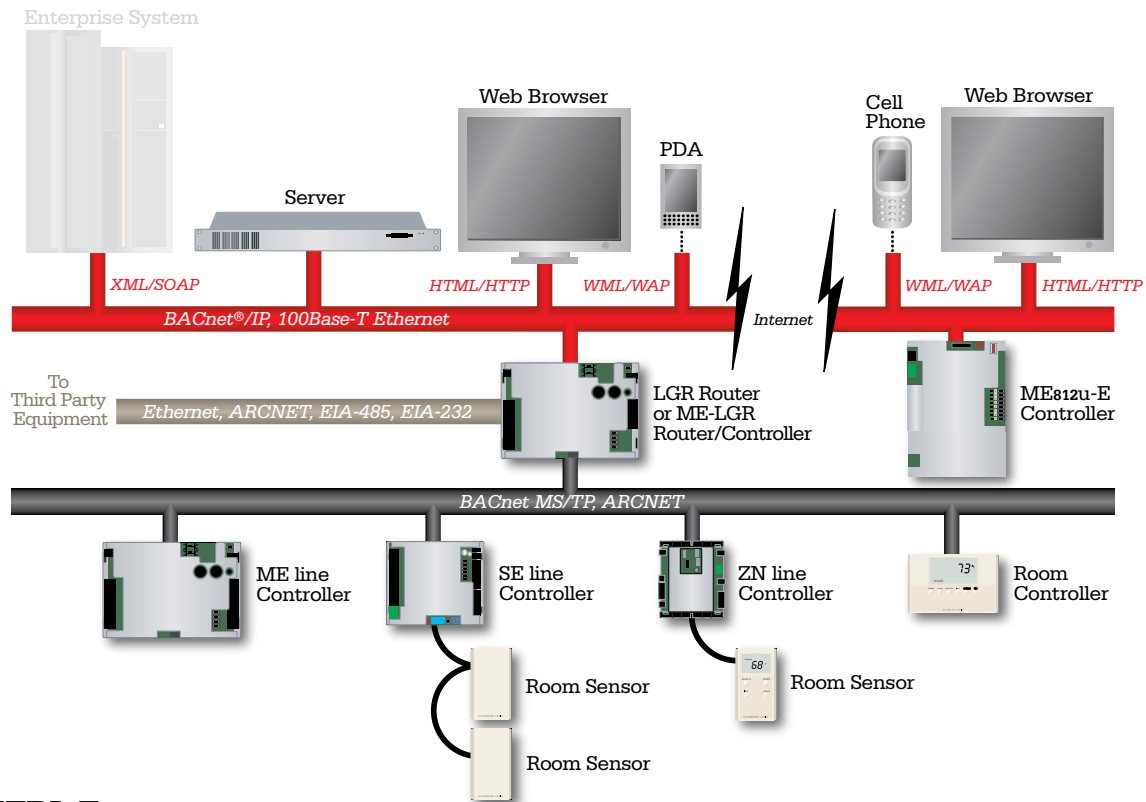

WebCTRL Features

Unlimited simultaneous users

Runs on MS Windows® (Vista, XP, 2003 Server), Red Hat Enterprise (Version 4 and 5), Sun Solaris

Includes Secure Sockets Layer with 128 bit encryption

Supports Oracle, MS SQL Express, MS SQL Server, PostgreSQL

Supports data exchange via XML/SOAP (Web Services)

Supports third party integration

Supports communication to field controllers via BACnet (TCP/IP)

Supports web appliances (Palm Pilots, Pocket PCs, Blackberrys, etc.)

Supports Hierarchical Server configuration for very large systems

Includes alarming, trending, scheduling, and reporting capability

Includes international languages (International English, Spanish, French, German, Korean, Traditional and Simplified Chinese)

Fully compatible with legacy ALC systems

